



▶▶ **PoE Lighting**
Application & Product Guide
For Today's Digital Lighting Systems



WWW.SIEMON.COM



▶▶ Connecting Today's PoE Lighting Systems to a Higher Standard

Advancements in light-emitting diode (LED) and IP-based technology, combined with the need to save energy, has given rise to the rapid adoption of commercial digital lighting applications with LED lighting fixtures that can be controlled and monitored over Ethernet-based networks and remotely powered using Power over Ethernet (PoE) technology. These advanced PoE lighting applications rely on a well-designed structured cabling infrastructure, electronics and software connecting and communicating with IP-based fixtures, nodes, dimmers, a host of sensors and controllers to deliver maximum performance, comfort and energy savings.

As a leading global manufacturer of low-voltage copper and fiber optic cabling systems, Siemon understands that high-performance cables and connectivity play an important role in supporting today's digital lighting applications and the delivery of PoE to lighting fixtures and devices.



PoE lighting is a key IoT enabler as a ubiquitous platform for advanced sensor technology and data collection throughout a building.



Why PoE Lighting?

While the energy savings, health benefits and longevity of LED lighting technology are undisputable, connecting and powering lighting systems over IP-based networks using PoE technology provides additional cost saving benefits. The deployment of a PoE network connection costs approximately 75% less than a traditional electrical installation to support lighting. Due to the sheer number of lights in a commercial building, PoE lighting therefore delivers significant cost savings over traditional AC lighting implementations with an estimated typical CAPEX savings of USD \$19.40 per square meter (USD \$1.80 per square foot).

In addition, a comparison performed by Cisco® of the upfront labor and installation investment and upfront hardware and software investment costs between traditional fluorescent, traditional LED and PoE lighting deployments clearly demonstrates that PoE lighting offers the lowest cost of ownership.

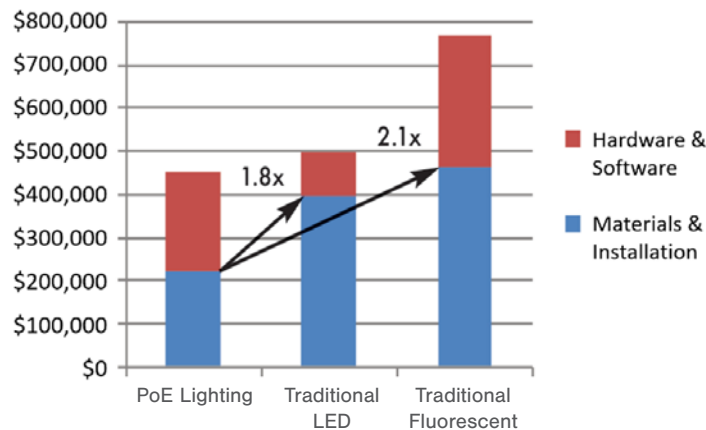

Benefits of POE lighting solutions:

- Delivers significantly lower capital and labor investment with lower operating costs
- Extremely safe low voltage operation
- Environmentally friendly with less emissions and no hazardous mercury
- Saves energy—LED lights consume half the energy of fluorescents and last 5X longer
- Centrally managed—Integrates with other applications and can receive centralized IT back up power
- Daylight harvesting, motion detection, smart shut off
- Intelligence to adapt to lighting levels and preferences based on users' needs
- Color coding and flashing patterns for security, fire and/or threat level notification
- LiFi network connectivity
- Provides a plug-and-play environment for application specific sensors

▶▶ Unlocking Lighting as a Platform

In today's intelligent building, having the right platform is critical to cost effectively supporting current and future building technologies. Sensors that detect and respond to changes in the environment can be embedded within PoE lighting solutions, enabling them to collect and share data with other connected systems. Because lighting is ubiquitous and each PoE lighting fixture is a node on the network, PoE lighting provides an ideal and pervasive platform. As technology advances, existing PoE lighting fixtures can easily be retrofitted with new plug-and-play sensor technology, avoiding costly and disruptive deployment of new infrastructure. Some building system technologies that can be embedded in PoE lighting solutions include:

- Occupancy, daylight harvesting and optical sensors to detect people and ambient/sunlight levels for adjusting lighting and temperature to save energy
- Temperature and humidity sensors for adjusting HVAC systems to improve comfort and efficiency
- Pressure, level and water-quality sensors to detect the presence of or changes in gases or liquids for leak detection, equipment maintenance, and waste and water management
- Proximity and accelerometer sensors that detect objects and movement for crowd detection and control, parking availability, wayfinding and assembly line optimization
- Gas sensors that detect changes in air quality and presence of combustible or toxic gases
- Infrared sensors to detect heat and movement for intrusion detection, body temperature monitoring and a variety of other healthcare uses
- Shot detection and other public safety-related sensors

Part of Siemon's ConvergeIT Intelligent Building Solutions

The integration of low-voltage applications is happening as part of the intelligent building movement, and PoE lighting is converging over an IP-based platform along with Wi-Fi, AV, security, distributed antenna systems (DAS) and building automation systems.

Siemon's ConvergeIT Intelligent Building Solutions includes Digital Building Architecture that supports the design, installation and administration of integrated systems and Digital Building Delivery that ensures a robust, scalable standards-compliant infrastructure, from construction planning through implementation and delivery.

This PoE lighting application and product guide is just one in a series for all the low-voltage applications that fall under Siemon's Digital Building Architecture and Digital Building Delivery. These guides are specifically developed to help our customers optimize the design, performance and administration of converged applications, while best fitting their technology roadmap and budget and ensuring return on investment



▶▶ Smart Lighting Evolves

As PoE lighting systems have gained momentum in the marketplace and network switch power capabilities have reached nearly 100W, a wide selection of fixtures has become available, ranging from common troffers for commercial office drop ceiling applications to task-oriented and high-end architectural lighting. These systems include a variety of sensor and controller devices. PoE lighting fixtures and devices also vary in how they are powered and connected to the network.

Types of Intelligent Lighting Systems:

Within the world of smart or intelligent lighting, there are two options for power and control delivery known as PoE (Power over Ethernet) and PaE (Power and Ethernet). Both PoE and PaE low voltage lighting solutions can utilize standard lighting control protocols and adhere to global standards to provide assurance that intelligent building solutions can be deployed without risk. For PoE systems, the LED drivers are typically present within every PoE fixture while for PaE systems, the LED driver can be placed at a centralised location. Hence for PaE-based solutions, the project specifier can choose to implement during any project design phase either a traditional lighting control system (DALI or DMX/RDM) or Ethernet-based control solution. Therefore, conventional lighting protocols can still be utilised whilst taking advantage of centralised low voltage lighting solutions.

POE Lighting Fixture Types

- Troffer style
- Surface mount
- High bay
- Industrial
- Strips
- Linear
- Downlights
- Cove lights
- Cylinder lights
- Sconce/wall mount
- Suspended/pendants
- Wraps
- Cove
- Emergency lighting
- Custom designed fixtures
- And many more...

Remote Powering Technology

Traditional LED lighting deployments utilized either dedicated DC power or inefficient AC/DC converters to deliver low-voltage power to LED lighting fixtures, typically ranging from 9 to 50 Watts depending on their size and lumens (i.e., brightness). The advancement of PoE technology now enables transmitting power over all four pairs of a twisted-pair cable to provide higher levels of power to energize LED lighting fixtures.

PoE Characteristics

Class	IEEE Standard	Designations	Max Power Delivered from Source (Watts)	Max Power Available per Device (Watts)	Powered Device Voltage Range (V)
0	802.3af (2 pair)	Type 1, PoE	15.4	12.95	37 - 57 V
1			4	3.84	37 - 57 V
2			7	6.49	37 - 57 V
3			15.4	12.95	37 - 57 V
4	802.3at (2 pair)	Type 2, PoE+	30	25.5	42 - 57 V
5	802.3bt (4 pair)	Type 3, PoE++, 4PPoE	45	40	42 - 57 V
6			60	51	42 - 57 V
7	802.3bt (4 pair)	Type 4, PoE++, 4PPoE	75	62	51 - 57 V
8			90	73	51 - 57 V

PaE Characteristics

Class	Pair Count	Designations	Max Power Delivered from Source (Watts)	Max Power Available per Device (Watts)	Powered Device Voltage Range (V)
0	4 Pair	IP Hybrid+	83.2	82.4	3 - 51.5V
1	4 Pair	IP Hybrid+	104	103	3 - 51.5V

When it comes to supporting digital lighting, there are additional considerations with respect to the cabling systems utilized. Not only is it important to follow TIA and ISO structured cabling standards and deploy Category 6A/Class E_A or higher connections to support all current and future digital lighting implementations, but superior support for PoE is also a primary consideration.

With higher level IEEE 802.3bt Type 3 (60W) and Type 4 (90W) PoE for powering LED lighting fixtures comes the potential for heat buildup within cable bundles and electrical arcing damage to connector contacts, which can lead to power and efficiency losses, performance degradation and the potential for damaged connecting hardware. Deploying a cabling infrastructure that delivers PoE requires shielded cables with improved heat dissipation and connectivity designed to provide superior remote powering support—that's Siemon's PowerGUARD® technology.



Only shielded cabling can ensure superior support for today's PoE lighting applications

Category 6A or Higher Shielded Cabling with PowerGUARD® Technology is the Best Choice for PoE Lighting Systems

- Un-mating a RJ-45 jack-plug connection while transmitting PoE produces an arc that potentially erodes the plated jack-plug contact surfaces at the arcing location. Should this erosion occur in the area of the fully mated position, the result is an unreliable connection that can cause degraded network performance and increased bit error rates.

Siemon's Z-MAX®, MAX® and TERA® jacks with PowerGUARD® technology feature a patented crowned jack contact shape that places arcing damage to both the plug and jack contacts away from the final mated position—allowing you to connect and disconnect to the latest remote powering applications with zero risk.

- Shielded Category 6A/Class E_A or higher cabling systems with PowerGUARD® technology offer improved heat dissipation to reduce heat buildup within cable bundles. This critical protection guards against temperature-related rises in insertion loss and premature aging of jacketing materials that can have an irreversible effect on transmission performance.
- Siemon shielded Category 6A/Class E_A and Category 7A/Class F_A systems with PowerGUARD® technology provide maximum support of remote powering applications with a higher 75°C operating temperature qualified for mechanical reliability in high temperature environments.



Other Jacks Damaged Fully Mated Position

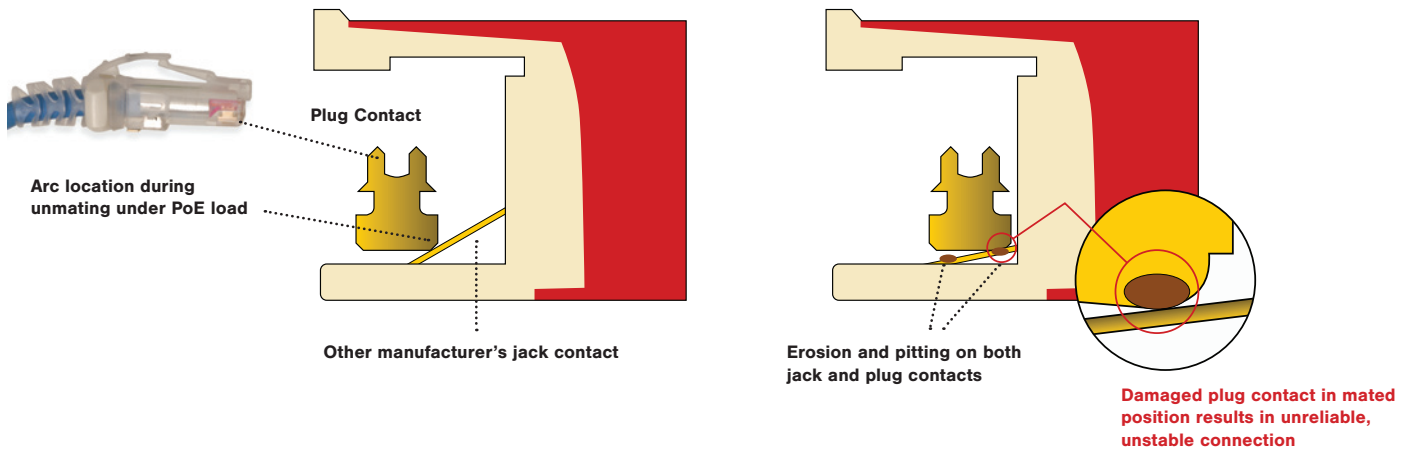

Siemon Jacks With PowerGUARD® Technology

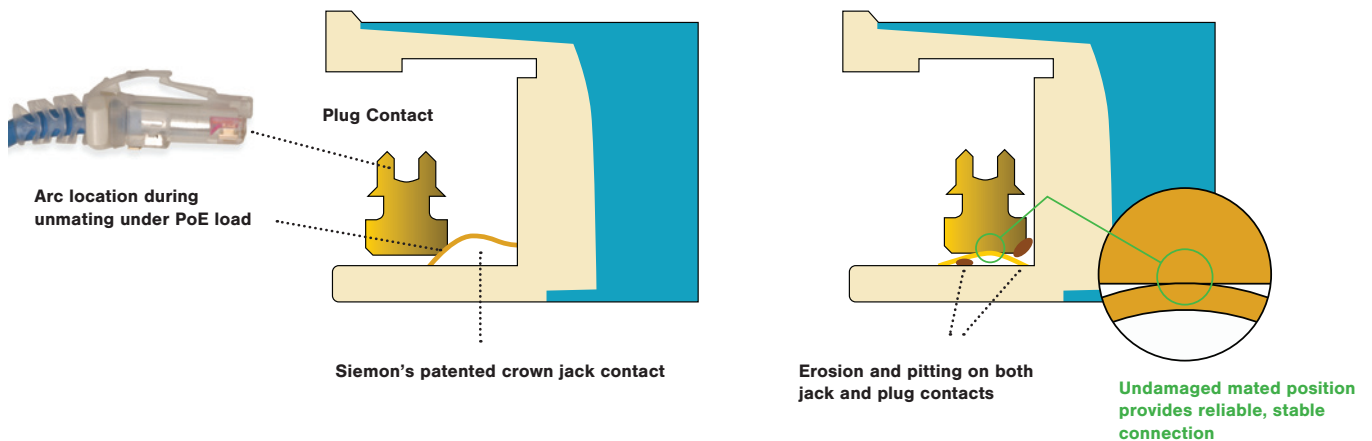

PoE Lighting Luminaire Configurations

In a smart PoE lighting design, structured cabling connects an Ethernet switch port capable of providing DC power directly to an LED lighting fixture or to a “node”, which branches power and data off to an LED lighting fixture or fixtures, a device such as a sensor, and a controller. In commercial environments, the LED lighting fixture is most often a troffer, but may be any type of luminaire design.

Depending upon the PoE lighting system, port power budget, troffer size, and manufacturer, one node may serve one or two troffers, up to 7 recessed “can” lights, as well as optionally incorporate a data port for control (e.g. a dimmer or a sensor). The node centric solution is one-to-many in nature, requiring fewer powered ports and less energy than a fixture centric architecture.

The most common LED lighting luminaire configurations are shown below. For all LED lighting luminaire configurations, the maximum power supported by each structured cabling channel and node, if present, is 100W although levels typically do not exceed 60W.

Node Centric

In a node-centric PoE lighting system, network connected nodes provide the interface for connecting fixtures, external sensors and controllers. The number of devices supported per node depends on the manufacturer and size and type of fixtures and devices. Depending on the manufacturer, some low-power devices like sensors, dimmers and controllers may be daisy chained. In most cases, a node-centric system is more flexible, can also connect to, power and control a variety of edge devices other than lighting, and offers the benefit of fewer cabling runs from the centralized PoE switch. Node-centric systems establish a platform for power delivery, data, and control, supporting other devices like mechanized shading, ceiling fans, and security equipment.

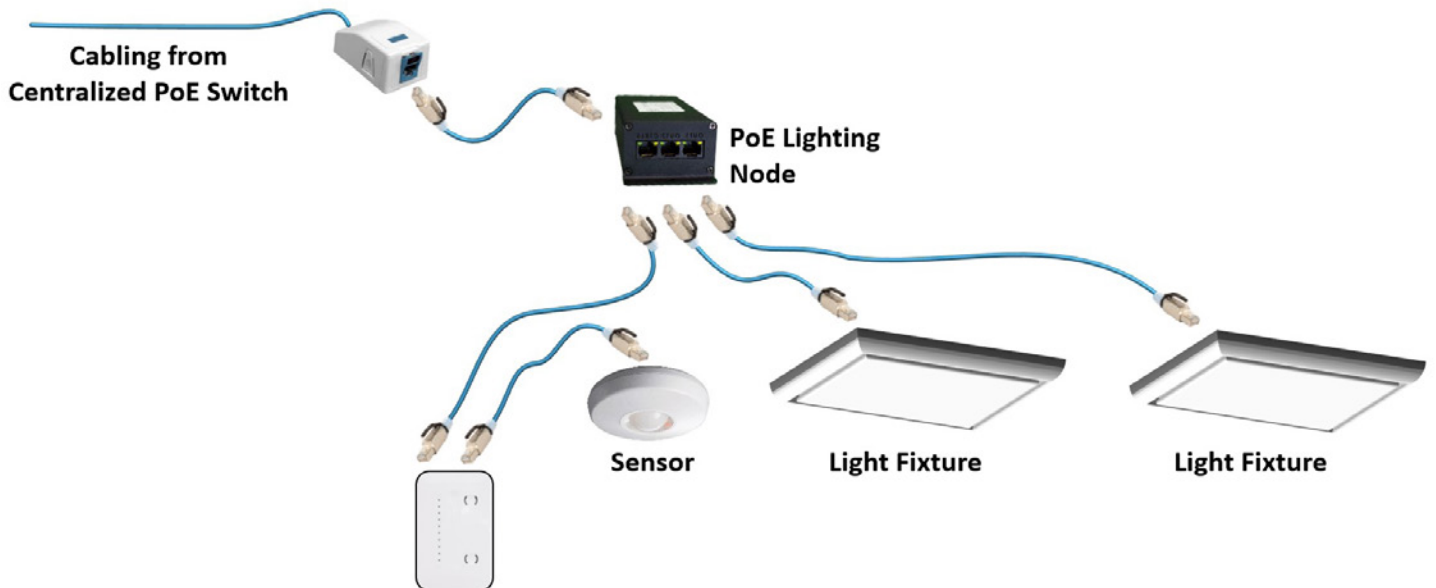

Fixture Centric

In a fixture-centric PoE lighting system, each lighting fixture or device has a built-in sensor and is connected to the centralized PoE switch. Depending on the manufacturer, low-power devices may be daisy chained or connected individually in this scenario. These systems have a denser sensor network and offer a more centralized management approach and can deliver higher levels of remote powering to devices.

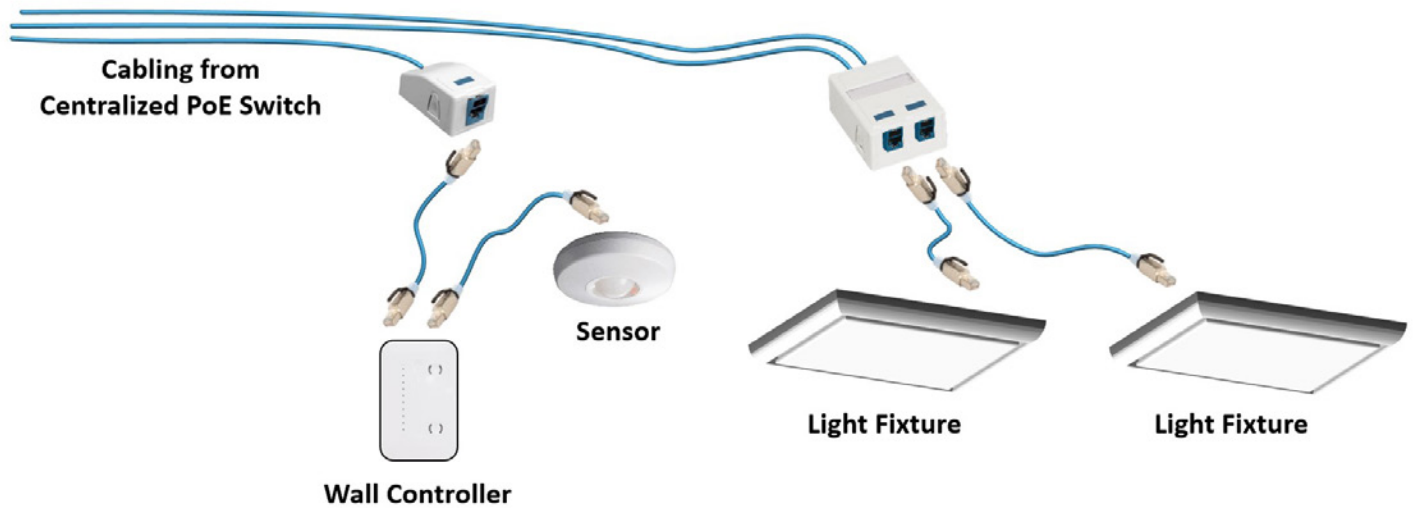

Centralized vs. Decentralized

Centralized systems place PoE switches in telecommunications rooms (TRs) while decentralized systems position smaller switches close to groups of lighting fixtures, often in the plenum air space. When all of the PoE switches are located in the TR, it is referred to as a “centralized” deployment. Even in the least dense centralized switch port solution, a PoE lighting system uses less than three full cabinets or racks per 100,000 square feet.

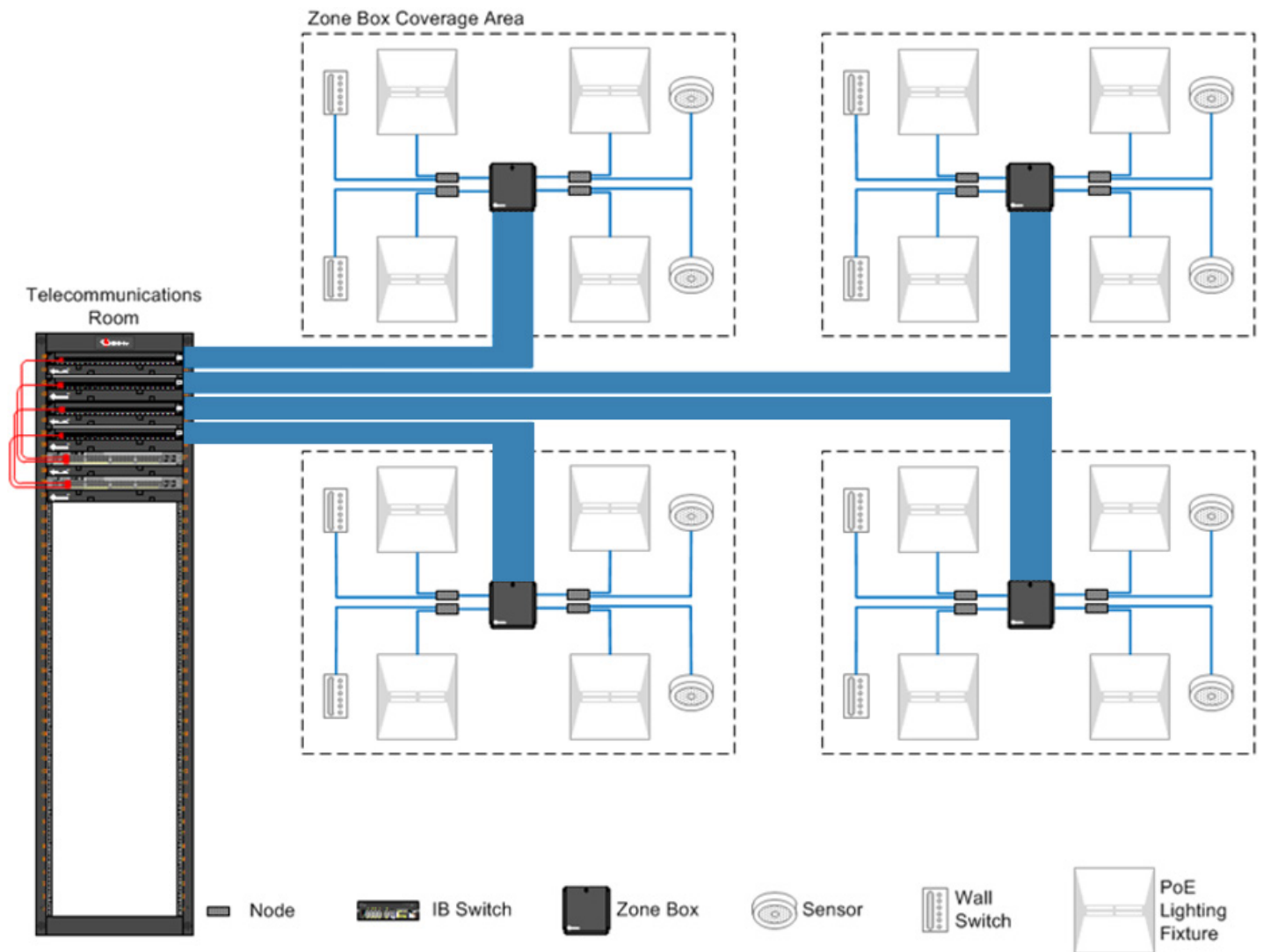

Centralized Zone–Node centric

In a decentralized approach, special industrial grade intelligent building PoE switches are distributed and located in the ceiling spaces. Siemon highly recommends the use of a centralized architecture as it can leverage the existing network power infrastructure, ensure adjacent fixtures are not powered by the same PoE switch and significantly ease maintenance with all work performed in a central location. The use of decentralized switches also introduces additional points of failure into the system and has the potential for multiple adjacent fixtures to be on the same PoE switch causing the possibility of a “dark” area, like a conference room, in the event of a switch failure.

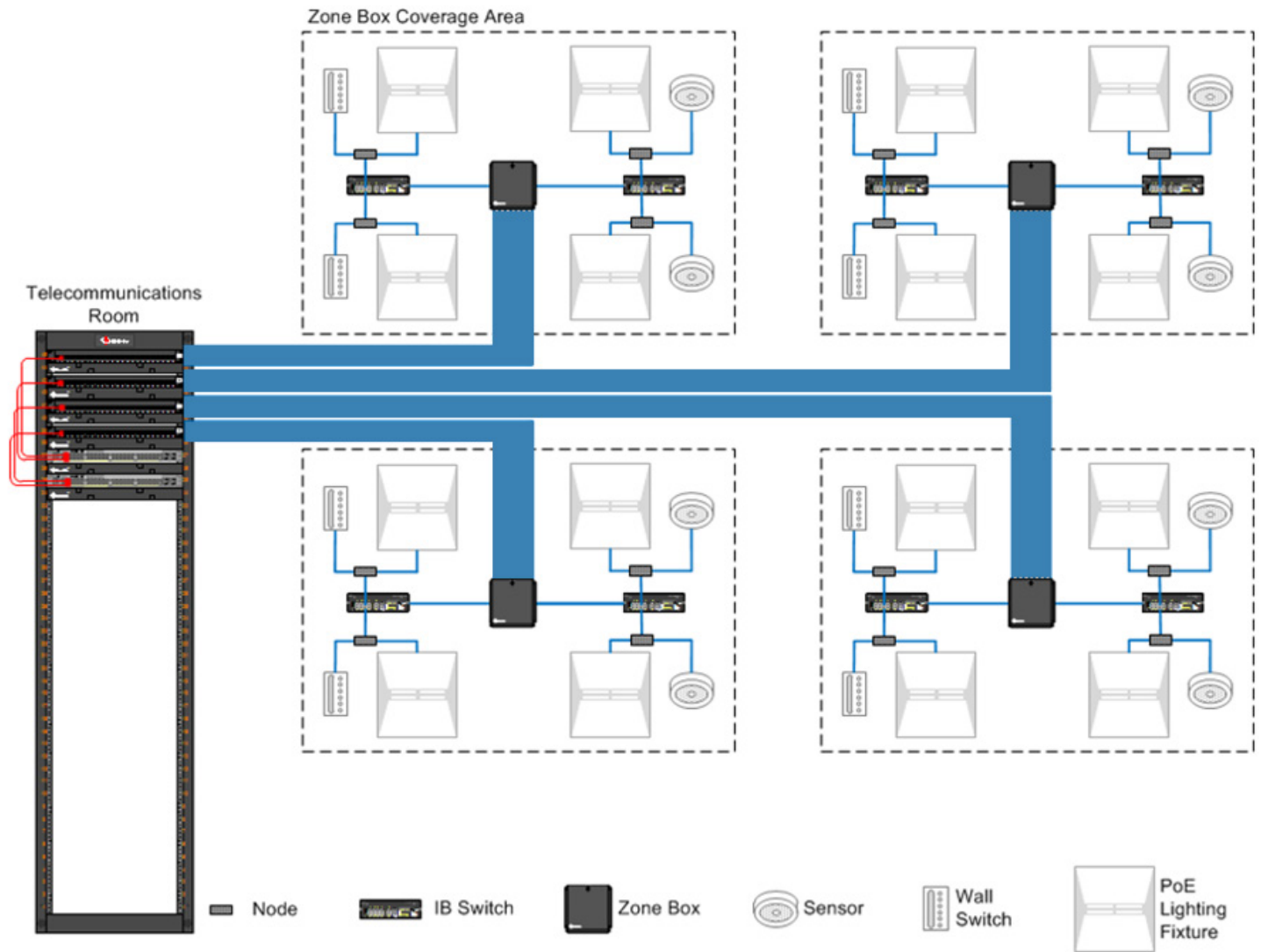

Decentralized Zone–Node centric

►► PoE Lighting Means Structured Cabling

Star Topology with Interconnect

While traditional LED lighting deployments utilized AD/DC converters and did not enable data communications, structured cabling standards governing IP-based twisted-pair systems for networked PoE lighting systems utilize a hierarchical star topology where each outlet serving end devices such as nodes, fixtures and controllers is connected to the switch via horizontal cable and patch panels in an interconnect scenario. As shown below in a star configuration with an interconnect, patching occurs directly between the PoE Ethernet switch and a distribution patch panel, enabling easier management and moves, adds and changes.

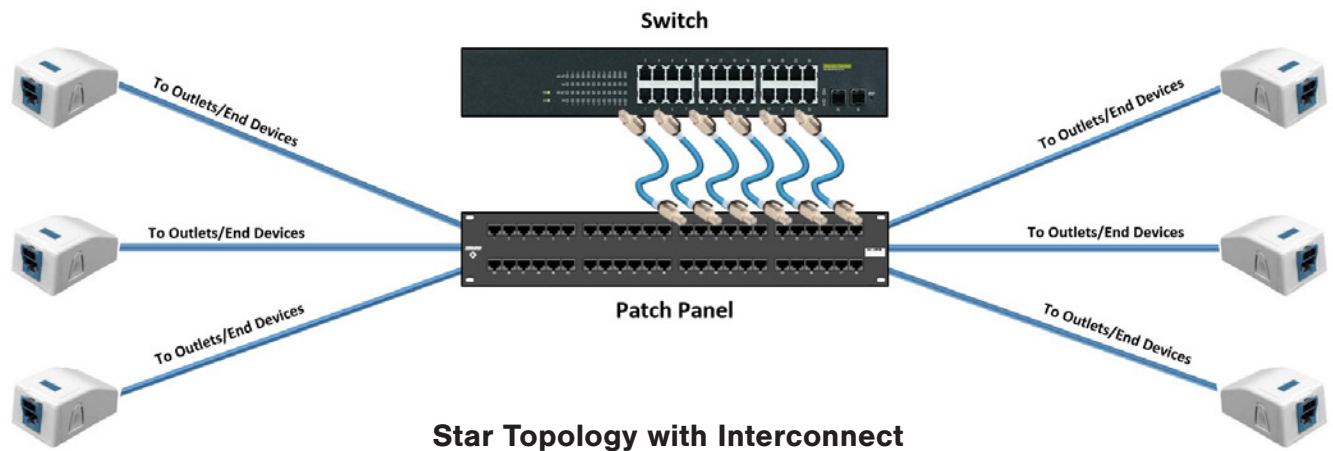

Horizontal Link Lengths

ISO/IEC and TIA industry standards limit copper horizontal channel length to 100m, consisting of the following:

- 4pair 100-ohm unshielded or shielded twisted-pair cabling
- 90m permanent link using solid conductor cable
- 10m of patch cords using solid or stranded conductor cable
- Maximum of 4 connectors within the channel

Extended distances may also be possible using fully shielded Category 7A/Class F_A cable depending on equipment/device vendor specifications.



Structured cabling standards from ISO/IEC and TIA are the foundation of IP-based networks supporting PoE lighting systems, establishing performance parameters and best practices that can reduce downtime and improve manageability.

Zone Cabling

Regardless of whether a PoE lighting system is node centric or fixture centric, it is highly recommended that the supporting cabling infrastructure be designed using a zone cabling topology. A standards-based zone cabling topology incorporates a horizontal consolidation point (HCP) or service concentration point (SCP) outlets typically housed in a zone enclosure that serves as an intermediate connection point between the patch panel in the telecommunications room (TR) and service outlets (SOs) or end devices. The benefits of zone cabling include:

- Fast, easy deployment of new lighting fixtures via spare port capacity in the zone enclosure, providing flexible, futureproof infrastructure for PoE lighting
- Rapid reorganization and less disruptive moves, adds and changes by isolating changes to the shorter cabling link between the zone enclosure and the SO or device
- Improved pathway utilization
- Great for dynamic spaces or tenant spaces that may need to be reconfigured between occupants

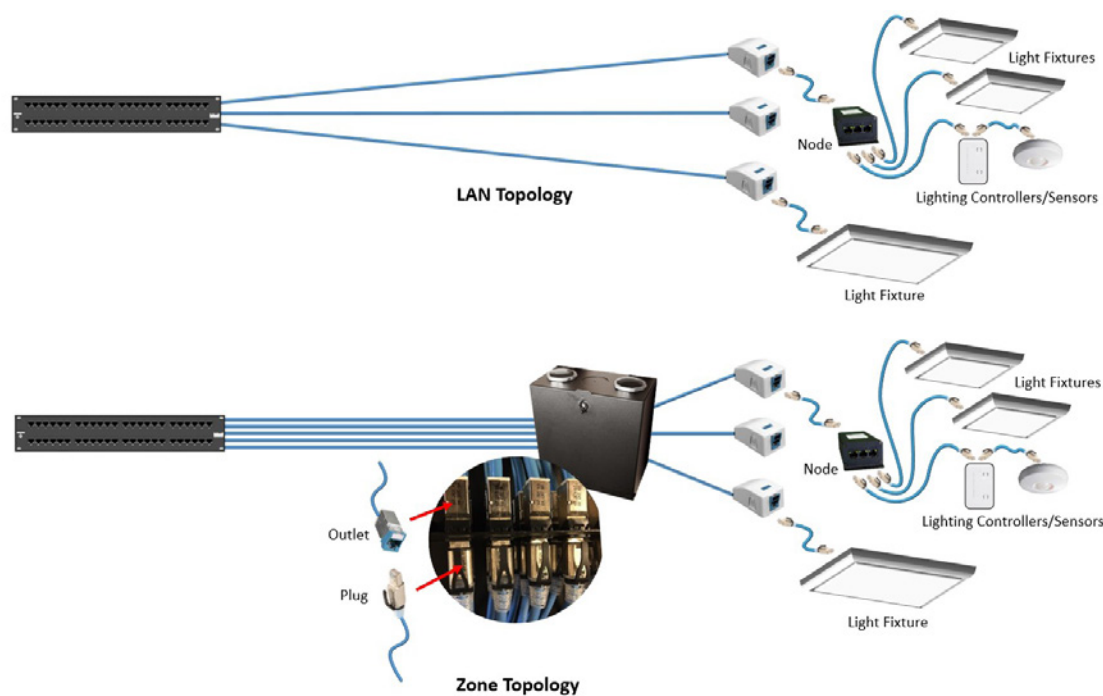

Zone vs. LAN Topology

Zone cabling is especially ideal for PoE lighting systems because they are most often designed with multiple fixtures arranged in grid-based lighting coverage areas throughout a building. The zone enclosures should be centrally located within their respective coverage area, and Siemon recommends that the number of available SCP connections within the zone enclosure should be no less than 24 (e.g., for small PoE lighting deployments) and should not exceed 96. Siemon recommends that PoE lighting device coverage areas be planned with a radius no greater than 13m (43ft), which translates to an 18m by 18m (60 ft by 60 ft) grid. Note that coverage areas in close proximity to the TR can be connected directly to patch panels in the TR without passing through an SCP. For optimized design efficiency, Siemon recommends that zone enclosures be positioned at least 30m (100 ft) from the TR. Because of the high number of PoE lighting devices in an enterprise space and the static nature of the lighting environment (there are few adds, moves, and changes), Siemon recommends that a dedicated zone enclosure provide SCP outlet connections for PoE lighting devices and a separate zone enclosure will provide SCP connections to all other building automation and IP devices. Siemon also recommends diverse cable routing practices to provide redundancy and partial lighting operation in the event of service disruption.

▶▶ PoE Lighting Cabling Configurations

Traditional Configuration

In a traditional LAN-style cabling configuration, horizontal cable is terminated to an SO with a Z-MAX® connector housed in a faceplate or surface mount box located near the device (i.e., lighting fixture, node or other lighting device). Patch cords are used to connect the devices to the SOs. The use of an SO provides a convenient end-user location to support labeling and administration of the cabling and identify channels for future use. To facilitate moves, adds and changes, a zone-style topology where shorter links run from outlets in the zone enclosure to the SOs can also be deployed.

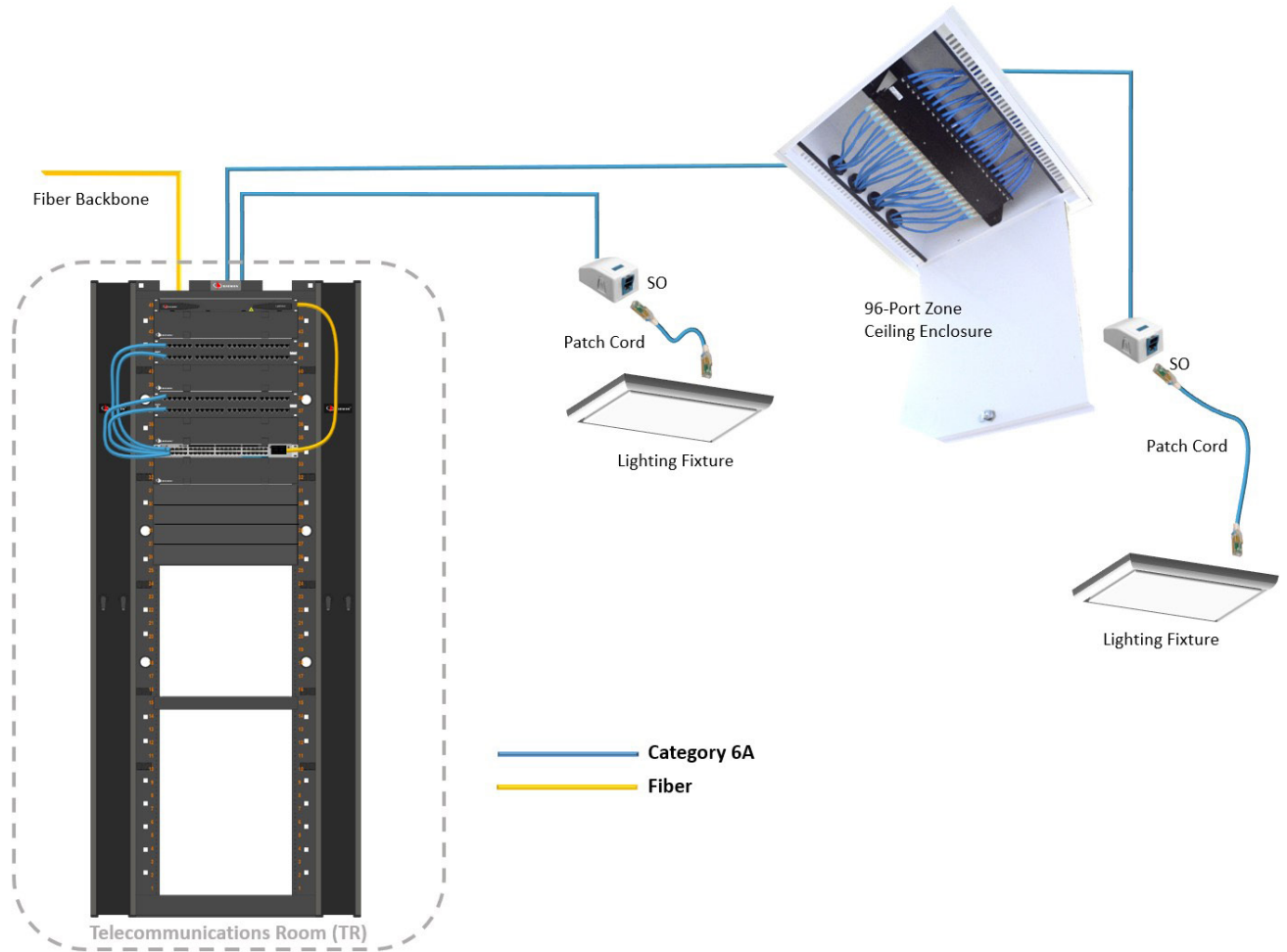

Traditional Configuration

Modular Plug Terminated Link (MPTL)

The MPTL topology eliminates both the service and SCP outlets and plugs the horizontal cable directly into the PoE lighting device (i.e. lighting fixture, node or other lighting device). In an MPTL, horizontal cables from the distribution panel in the TR are terminated to field-terminated plugs (Z-PLUG™) and connected directly into the end device, essentially creating a one-connector channel. MPTLs often support applications-specific commissioning when the lighting fixture is not expected to be moved or rearranged after deployment.

To facilitate moves, adds and changes, it is strongly recommended that an MPTL be deployed in a zone topology where field-terminated shorter links run from outlets in a zone enclosure (96-Port Zone Ceiling Enclosure) to the devices. MPTL configurations using a zone topology are a two-channel configuration.

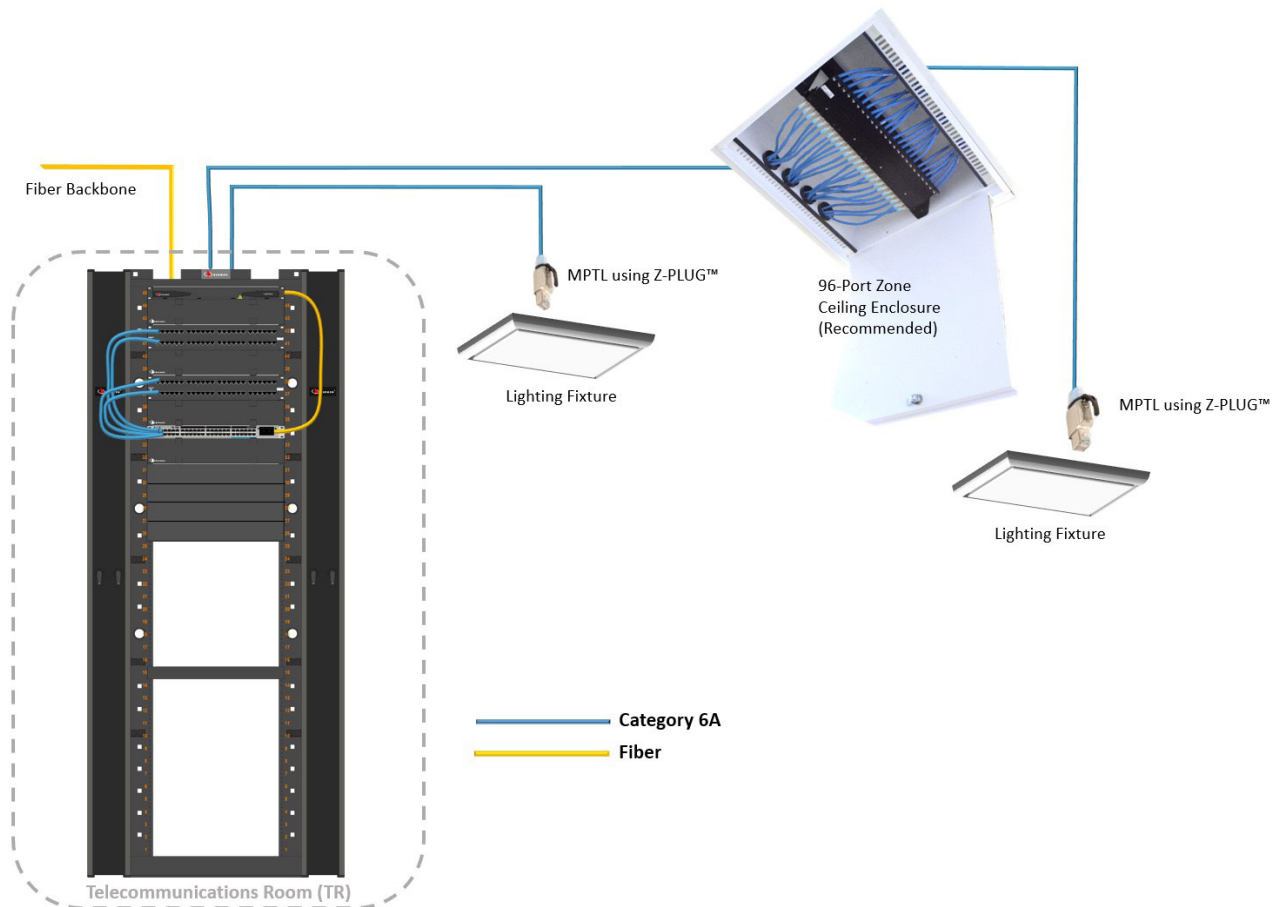

Modular Plug Terminated Link (MPTL) Configurations

Plenum Space Requirements for North America

In accordance with the National Electric Code® (NFPA 70), plenum-rated components that meet UL 2043 requirements for smoke and heat release are required when located within a building's in air-handling spaces, including above drop ceilings and under raised floors.

Siemon's cable, zone enclosures, outlets, plugs, patch cords and service mount boxes all meet UL 2043 requirements for providing connectivity in the plenum space to PoE lighting nodes and ceiling-mounted fixtures and sensors.

Industry Leading Solutions, Support and Strong Partner Network

As an industry leader, Siemon participates in global cabling standards development initiatives and is dedicated to understanding and supporting the unique needs of the market. With high performance copper cabling and innovative, easy-to-deploy connectivity solutions, Siemon delivers standards-based end-to-end cabling systems with the performance and reliability to support emerging PoE and PaE lighting systems. Siemon's LightHouse™ Advanced Fiber Solutions support backbone, switch and extended distance connections while our full range of racks, enclosures, and cable management solutions support and protect active equipment and connections.

Siemon offers technical support and expert guidance on designing and deploying high-performance, reliable cabling systems for PoE and PaE lighting systems. Siemon's ConvergeIT Intelligent Building Ecosystem brings together Siemon's advanced cabling systems and intelligent building expertise with a team of like-minded certified Digital Lighting Partners and innovative Smart Partners (SPs) with intelligent building design and integration expertise to help customers around the world build profitable intelligent buildings. Along with other intelligent building and PoE lighting experts, Siemon is a founding partner and the only end-to-end solution partner within the original Cisco Digital Ceiling / Building Ecosystem that promotes converging previously disparate systems on a single IP network with a keen focus on intelligent low voltage lighting.

Install with Confidence

Because of the wide range of expertise needed to specify, install, and manage the many components in a PoE lighting system, most customers rely on a lighting engineer or architect to design a reflected ceiling plan (RCP) for the building space. When it comes to installing the lighting system, it's important to leverage low-voltage installers who understand the nuances of properly deploying infrastructure to support PoE lighting systems.

Siemon's certified Digital Lighting Partners (DLPs) are specifically trained and have the resources they need to deploy high-performance, quality network infrastructures to support and install PoE lighting and intelligent buildings. Using Siemon DLPs ensures you are working with qualified installers that are:

- **Thoroughly trained and educated** via Siemon's custom DLP certification program, educational resources and exclusive continuing education
- **Backed by comprehensive sales and technical support** that includes a digital lighting showcase at DLP locations
- **Strategically aligned** with Siemon Smart Partners and design experts to ensure you receive the right PoE equipment, digital lighting and intelligent building solution.





Platformatics®



Application-specific cabling considerations are an integral part of Siemon's Digital Building Architecture



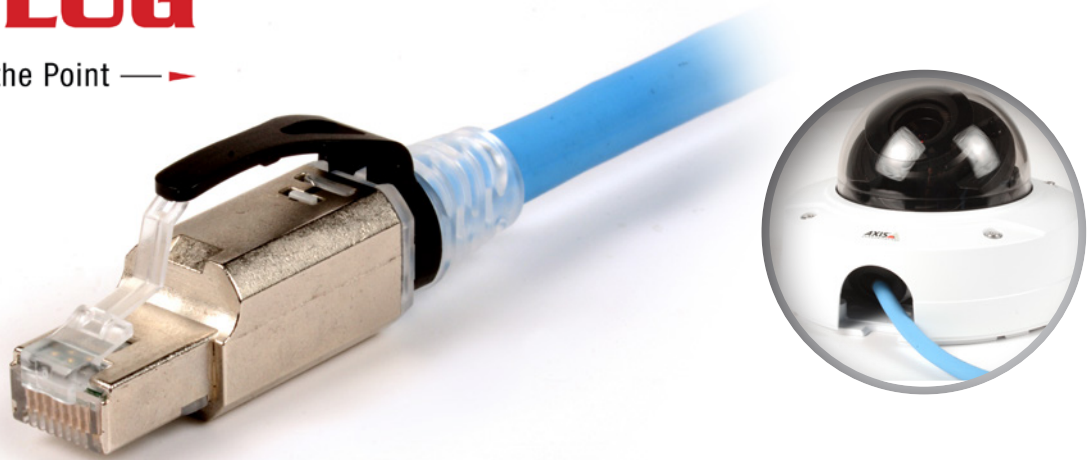

Z-PLUG™ Field-Terminated Plug

Siemon's patented Z-PLUG Field-Terminated Plug offers quick, reliable high-performance field terminations for custom length direct connections to security devices. Z-PLUG exceeds all category 6A performance requirements to easily support current and future security devices.

- Terminates shielded and UTP, solid and stranded cable in conductor sizes from 22 to 26 gauge – all with a single part number
- Features shorter plug design with rounded edges and the ability to eliminate the boot and latch protector makes it ideal for connecting to devices with limited space
- The user-friendly Z-PLUG termination tool and intuitive hinged lacing module that eliminates cable feed through enables best-in-class termination speed and repeatable performance
- Dual-purpose latch protector clip is available in nine colors for easy identification of various applications and devices
- PowerGUARD® technology with fully-shielded, 360-degree enclosure and 75°C operating temperature improves heat dissipation for PoE and PoH

go.siemon.com/PoEZplug

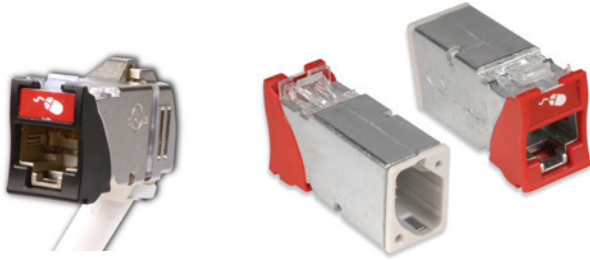

Z-MAX® Shielded and UTP Outlets

Z-MAX category 6A shielded and unshielded outlets combine exceptional performance with best-in-class termination time. Also available in a Z-MAX 45 category 6A version for terminating cable at a 45-degree angle in shallow back boxes or wall-mounted raceway systems. All Z-MAX products features PowerGUARD® technology to prevent erosion due to arcing when a plug is unmated while under DC remote power load.

go.siemon.com/PoEOutlets



TERA-MAX and Z-MAX Patch Panels

Available in flat and angled versions, TERA-MAX patch panels provide outstanding performance and reliability in a modular solution for equipment rooms. Shielded and UTP Z-MAX modules can be easily configured in the TERA-MAX and Z-MAX panels.

go.siemon.com/PoETERA



Z-MAX® Category 6A Modular Patch Cords

Ideal for facilitating connections to surveillance cameras from a service outlet or for patching in the telecommunications room, Siemon Z-MAX category 6A UTP and shielded cords offer the unparalleled performance of an exclusive PCB-based smart plug, alien crosstalk resistant construction and a host of innovative end-user features.

go.siemon.com/PoEZMAX



MAX® Faceplates

Available in double- and single-gang for housing up to 12 modules, durable MAX faceplates are designed to be used with angled or flat Z-MAX outlets.

go.siemon.com/PoEFaceplates

▶▶ End-to-End Copper Cabling Systems for Wi-Fi



Z-MAX® Surface Mount Boxes

Siemon's plenum-rated surface mount boxes offer an option where an outlet cannot be recessed into a wall or floor box. They support Z-MAX outlets and come in 1, 2, 4 and 6-port configurations.

go.siemon.com/PoESurfaceMount



Surface Pack Boxes

Siemon's plenum-rated surface pack boxes are ideal for mounting to a fixed location above the ceiling to support up to six ceiling-mounted surveillance cameras or other security devices. They support Z-MAX outlets and come in 3- or 6-port versions.

go.siemon.com/PoESurfacePack

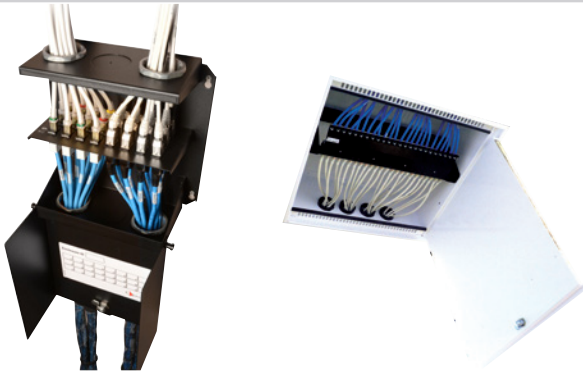

Zone Cabling Enclosures

Ideal for supporting zone cabling topologies, Siemon plenum-rated zone enclosures come in a 24-Port MAX Zone Unit Enclosure and a 96-Port Passive Ceiling Zone Enclosure that accept flat Z-MAX outlets.

go.siemon.com/PoEZone



Ruggedized Outlets, Plugs and Patch Cords

Siemon Ruggedized category 6A outlets, patch cords and plugs are the answer for security deployments in harsh environments such as laboratories, hospitals, cafeterias or any other place where connections may be exposed to dust, moisture or chemicals.

go.siemon.com/PoERuggedized

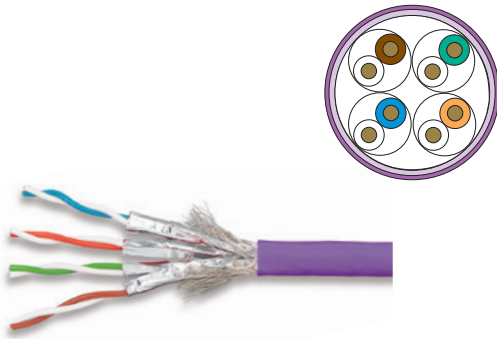

Category 7_A S/FTP Cable

Category 7A fully shielded cable is the highest-performing and most secure twisted-pair copper system available for connecting security devices, featuring excellent noise immunity and heat dissipation for optimum signal transmission and remote powering support.

go.siemon.com/PoECat7a

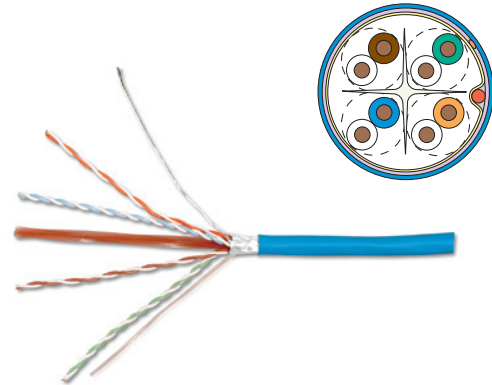

Category 6A UTP and F/UTP Cable

Our category 6A UTP and F/UTP cables feature the highest performance margins across all critical transmission parameters, which are the perfect solution for today's security applications where reliable throughput is paramount.

go.siemon.com/PoECat6a

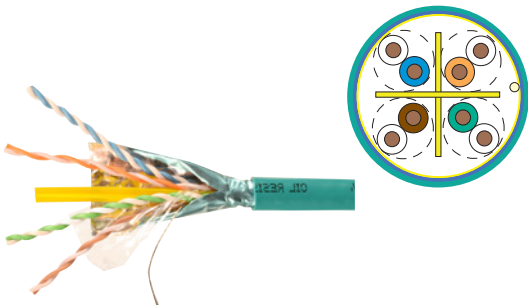

Category 6A UTP and F/UTP Indoor/Outdoor Cable

Our category 6A UTP and F/UTP indoor/outdoor cables offer oil and sunlight resistance, as well as cold bend performance, for easily transitioning from indoor to outdoor environments when connecting outdoor surveillance cameras where cable is not subject to long-term emersion and does not have to be direct buried.

go.siemon.com/SECOutdoorCable

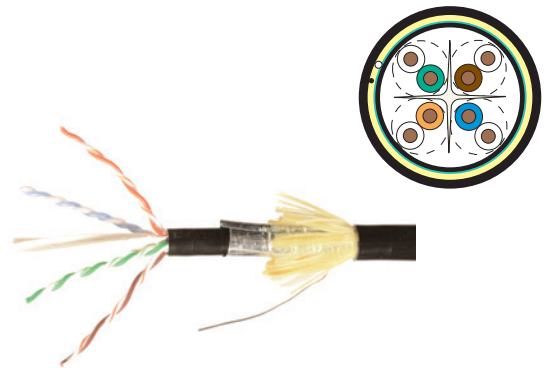

Category 6A UTP and F/UTP Outside Plant Cable

Our category 6A UTP and F/UTP OSP cables are designed to support the latest IP-based security applications in outside wet environments. Suitable for direct burial, lashed aerial, duct and underground conduit installations.

go.siemon.com/SECOutsidePlant



LightBow™ Fiber Termination Kit

Fiber optic cabling is ideal for security deployments that require greater than 100-meter distances, and Siemon's LightBow Mechanical Splice Termination System is a simple termination system that makes fiber deployments faster and easier than ever before without the cost and learning curve required for other fiber termination methods. LightBow's patented, easy-to-use termination simplifies fiber insertion and avoids connector damage, offering significant time savings and ensuring consistent, reliable performance.

- Factory assembled singlemode (UPC and APC) and multimode LC and SC simplex connectors
- Low-cost, simple robust termination process that combines splice activation and mechanical crimping to reduce termination time
- Built-in verification window on connectors for use with 0.5mW visual fault locator (VFL)
- Connectors can be adjusted after verification and re-terminated
- Termination kit includes LightBow termination tool, strippers, precision cleaver, strip template, VFL and everything needed for termination – all in a convenient carrying case
- Compatible with Siemon and Corning Unicam® cleaver

Note: Unicam is a registered trademark of Corning Cable Systems

go.siemon.com/PoELightBow



RIC Fiber Enclosure

Siemon's Rack Mount Interconnect Center (RIC) Enclosures offer secure, superior fiber density without sacrificing protection and accessibility. Used with Siemon's Quick-Pack® adapter plates, RIC enclosures are available in 2U, 3U and 4U, as well as in preloaded versions to save time.

go.siemon.com/PoERIC

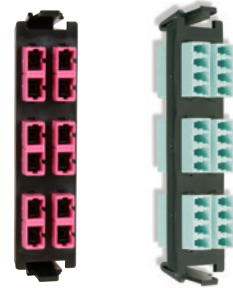

Quick-Pack® Adapter Plates

Siemon's Quick-Pack Adapter Plates are available in a wide range of fiber connector types, including LC, SC, ST and MTP, and can be easily installed into Siemon RIC enclosures to facilitate backbone or extended distances for security LAN applications.

go.siemon.com/PoEAdapterPlates

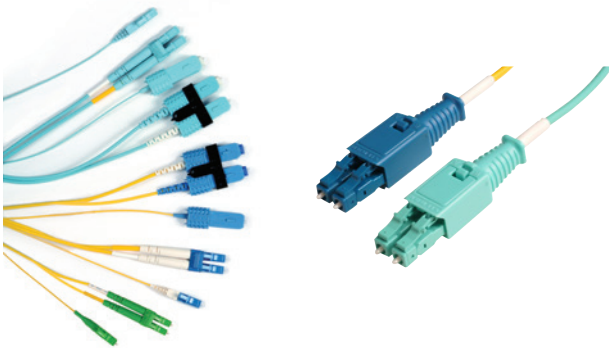

LC BladePatch® and XGLO Fiber Jumpers

LC BladePatch OM4 multimode and singlemode LC fiber jumpers offer an innovative push-pull action for high-density environments, while XGLO Fiber Jumpers come in both standard SC and LC for connecting switches and devices.

go.siemon.com/PoELCBlade



Fiber Cable

Siemon offers a full line of indoor, indoor/outdoor and outside plant bend-insensitive bulk singlemode and multimode cables available in tight buffer and loose tube and in a variety of jacket ratings for extended distances and campus-wide security applications.

go.siemon.com/PoEFiberCable



Value Rack

Siemon's Value Rack provides an economical, durable solution for mounting and securing cabling and active equipment in telecommunications rooms, and features integrated bonding and grounding and visible U space markings.

go.siemon.com/PoEValueRack



4-Post Rack

Siemon's adjustable-depth, 4-Post Rack provides a stable platform for mounting extended depth/size active equipment.

go.siemon.com/PoE4Post



Value Vertical Cable Manager

The Value Vertical Cable Manager is an economical, full-featured solution with every aspect optimized to minimize assembly time and simplify steps. This versatile manager is ideal when used with the economical Value Rack.

go.siemon.com/PoEValueVertical



Wall Mount Cabinets

The wall-mount cabinet is ideal as a mini telecommunications room or for remote distribution and consolidations points to deliver security in open, unprotected spaces such as warehouses, retail facilities and schools.

go.siemon.com/PoEWallMount



RouteIT Horizontal Cable Managers

RouteIT horizontal cable managers are available in multiple sizes and its high-capacity fingers can accommodate over 48 category 6A cables.

go.siemon.com/PoERoutIt



Cabling Tools & Testers

From cable prep and easy-to-use, innovative termination tools for Siemon copper and fiber connectivity, to visual fault locators and versatile hand-held testers, Siemon offers a variety of cabling tools and testers.

go.siemon.com/PoETools

▶▶ Want to Learn More About PoE Lighting?



Visit the Siemon.com PoE lighting application page: go.siemon.com/PoELighting



24/7 Customer Support: Customer_Service@siemon.com



Phone: (1) 860 945 4200
Customer Service: (1) 866 548 5814 (toll-free US)



Where to buy distributor locator: go.siemon.com/PoEDistributors

Because we continuously improve our products, Siemon reserves the right to change specifications and availability without prior notice.

North America

P: (1) 860 945 4200

Asia Pacific

P: (61) 2 8977 7500

Latin America

P: (571) 657 1950/51/52

Europe

P: (44) 0 1932 571771

China

P: (86) 215385 0303

India, Middle East & Africa

P: (971) 4 3689743

Siemon Interconnect Solutions

P: (1) 860 945 4213
www.siemon.com/SIS

Mexico

P: (521) 556 387 7708/09/10